

## CS100T Made in Canada

### Robust encapsulation:

The proven CS encapsulation using ethyl vinyl acetate and metal impregnated tedlar composite back ensures high resistance against ultra violet rays, high ambient temperatures and in the most extreme weather conditions. The thermal hardened glass protects the module from impacts and increased static stress.

### Simple Mounting:

CS100T modules are supplied with junction box with wire and connectors for easy interconnection of the module without use of special tools. The holes in aluminum frame allow easy and universal mounting.

### Anodized Aluminum Frames:

Our corrosion resistant frames are constructed to withstand wind speeds in excess of 200Km/h (125 mph) in typical ground mounted applications.

### More energy:

Independent surveys have shown that under realistic conditions such as low sunlight intensity or high temperature CS 100T modules produces approximately 20% more energy per rated Wp than crystalline modules.

### Excellent value for money:

The optimal use of raw materials and high standard of quality manufacturing processes ensures high performance and environmental reliability.

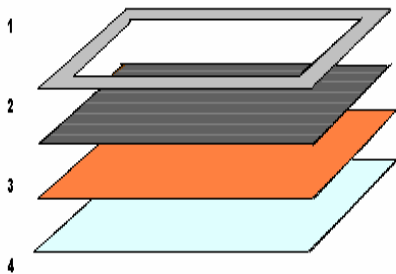

## Amorphous Solar Module:

### Performance and Reliability

Centennial Solar products are designed and constructed to provide high performance and reliability. We constantly improve our product to ensure product performance and reliability.

### Features

- High efficiency and reliability for diverse grid and off-grid applications
- Superior energy generating kWh/ kWp performance

### Applications

- Building Integration
- Solar Power Packs and Plants
- Solar Pumping Systems
- All Power Requirement



### Laminate Options

Centennial Solar also supplies laminates, enabling easy integration of products into third party solar electric systems or directly into building structures.



Constructive characteristics:

- 1) Frame of anodized aluminum, pre-drilled for quick and easy assembly.
- 2) Glass with thin film deposition of 4mm thickness.
- 3) Ethyl Vinyl Acetate (EVA).
- 4) Tedlar Aluminum Composite Backsheet.

## Guarantees :

The materials making the photovoltaic modules and any possible defects due to the manufacturing process for 2 years.

A power provided by the photovoltaic module of at least 90% of the minimum output power for 10 years.

A power provided by the photovoltaic module of at least 80% of the minimum output power for 20 years. Measured under Standard test conditions. (STC=1000W/m<sup>2</sup>, 25°C, AM 1.5).

The electric characteristics of each photovoltaic module are individually monitored and the results are left at the disposal of the customer.

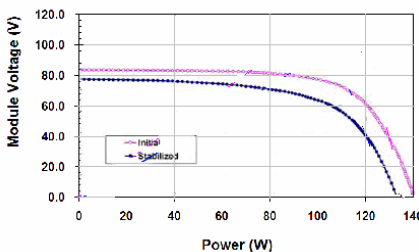
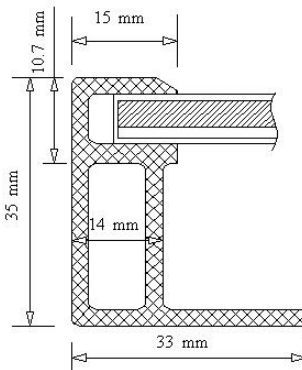
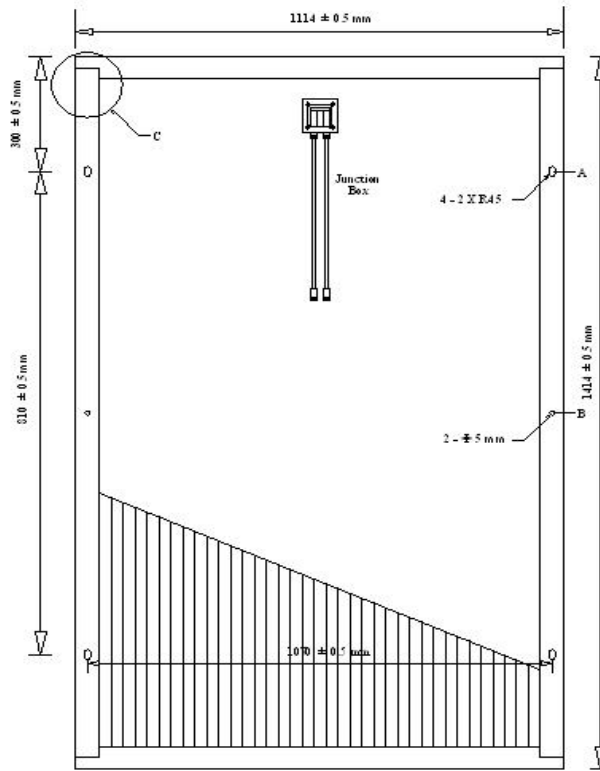

Specifications:	
Cell	Amorphous Silicon
Dimension of module (mm)	1114mm x 1414mm x 35mm
Weight (kg)	19.5
Characteristics:	
Model	CS100T
Average stabilized performance at STC	
Rated power (Pmax)	100W ±5%
Open circuit voltage (Voc)	100V±5%
Optimum operating voltage (Vmp)	76±5%
Short circuit current (Isc)	1.65A ±5%
Optimum operating current (Imp)	1.32A±5%
Module Efficiency	7.69%
Type of output Terminal	Junction Box
Cable lengths	0.8M long, 2.5mm
Connection	Type MC 1
Certificates	IEC616146 and IEC61730
Limits:	
Operating temperature	-40 to +85 °C
Maximum system voltage	1000V D.C
Temperature and coefficients:	
Nominal Operation Cell Temperature	45 °C
Current temperature coefficient	0.08%/°C
Voltage Temperature coefficient	-0.32%/°C
Power temperature coefficient	-0.2%/°C
Optimum voltage temperature coefficient	-0.28%/°C
Maximum over current protection rating	2.7A

Note: The specifications are subject to change without notice .

CONTACT  
**Centennial Solar Inc.**  
[info@centennialsolar.com](mailto:info@centennialsolar.com)

8114-B, Trans Canada  
 St. Laurent, Quebec, CANADA H4S 1M5  
 Tel: 514-461-9822 | 514-461-9823  
 Fax : 514-461-9824