



MFC 322T02 – DC - LAN

MFC 322T02 – DC - WLAN

IO – board with Ethernet Interface

Users manual

Copyright Intronico GmbH 2007 - All rights reserved

Intronico GmbH
Adalbert-Stifter-Str. 1
94469 Deggendorf
Germany

info@intronico.de
www.intronico.de

All mentioned products and brand marks are property of their legal owners.

V1.1

Disclaimer

The content of this publication was carefully examined for agreement with the hardware and software described. Nevertheless, discrepancies cannot be ruled out. Any liability and warranty for the accuracy of this information is excluded.

Content

1. The MFC 322T02-DC-LAN (WLAN) I/O-board	3
Description	3
Target users	3
Proper use	3
Improper use	4
Scope of supply	4
Certifications	4
2. Hardware	5
Overview	5
Power supply	5
Inputs	6
Digital - Inputs	6
Temperature - inputs	7
Temperature / humidity - measurement	8
Outputs	9
Relay - outputs	9
3. Ethernet connection	11
Point-to-point connection	11
Network connection	11
Connecting the W-LAN antenna (only MFC 322T02-DC-WLAN)	11
4. Installation and putting into operation	12
Installation	12
Readiness	12
Status display	13
Retention	13

5. Technical Data.....	14
General.....	14
Digital – Inputs.....	14
Temperature – Inputs	14
Combined temperature & humidity input	14
Relay – Outputs.....	15
Ethernet Interface (MFC 322T02-DC- LAN).....	15
Wireless LAN Interface (MFC322T02-DC -WLAN)	15
Dimensions [mm].....	16

1. The MFC 322T02-DC-LAN (WLAN) I/O-board

Description

The MFC 322T02-DC IO-board is an easy and low-cost solution for professional control and monitoring tasks. It is designed for professional integration in industrial machinery, office- or household devices, metering- and monitoring devices, etc. The board provides digital and analog inputs and outputs.

Target users

The MFC 322T02-DC IO-board is for professional control-engineering applications. OEM-manufacturer use it for integration in industrial machinery, switchboards, office- or household-devices. It is also suitable for use as a “stand-alone”-controller in facility management- or laboratory-applications.

Proper use

MFC has to be installed according to the established safety and EMC regulations. When applied with voltages that exceed the low-voltage range of 24VAC or 60VDC, it has to be installed in a suitable enclosure or distributional board, that prevents accidental contact with live parts.

When applied in control circuits, where objects or persons could be harmed, qualified personal has to assure proper installation and parameterization prior to put the MFC into operation.

When putting the MFC into operation, it has to be assured, that sudden movements, heating or energizing of electrical installation, initiated by the MFC, do not cause any harm to objects or persons.

Improper use

It is not authorized to use the MFC in safety-related control circuits and life supported devices as for example:

- Elevator or crane controls
- Emergency stop controls
- Two-hand safety controls
- Burner controls
- Medical related equipment, especially when it supports or sustains life

Scope of supply

- MFC 322T02-DC I/O-Board
- CD with software examples and manual

Certifications

MFC 322T02-DC complies with the established European RTTE standards. After installation in its destined place, CE-conformity has to be verified.

2. Hardware

Overview

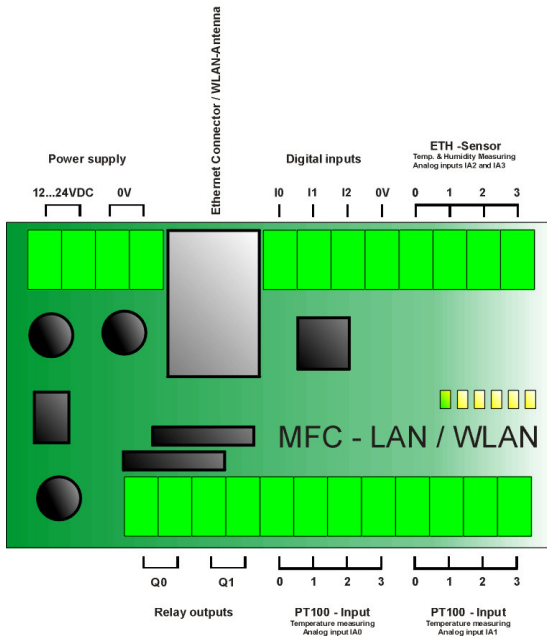

Power supply

The MFC-board has to be supplied with a DC-Voltage in the range of 12...24 VDC (+/- 10 %). The supply input is equipped with a varistor to prevent the circuit from overvoltage transients.

Supply terminal-blocks are equipped with 2 terminals each, to allow bridging to additional components.

The MFC-board is protected against damage due to inverse connection.

Inputs

Digital - Inputs

Inputs **I0**, **I2** und **I3** are digital inputs, which means the input may have 2 states – high or low. The state of each input is displayed by a coordinated LED on the board. The inputs have to be connected according to the polarity indicated in fig. 3.

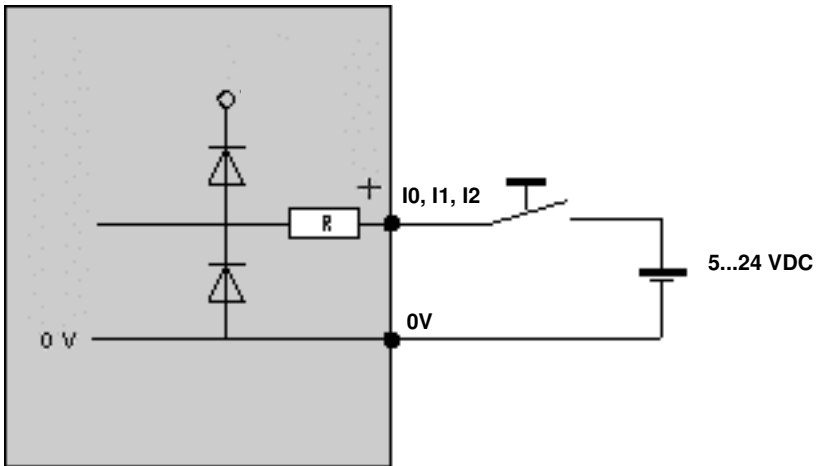
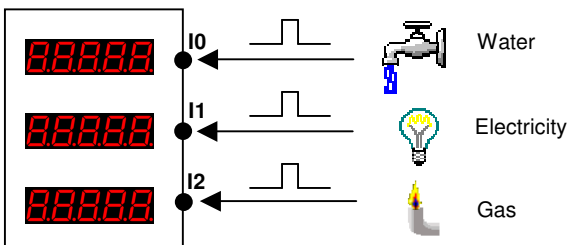

fig. 3 – digital inputs

All digital inputs may be used as counter-inputs. Each input is able to capture pulses with a frequency of up to 50 Hz. Counter states are stored on the board independently of the supply voltage. The counter inputs are especially useful to capture consumption-pulses of water, gas or electricity.



Temperature - inputs

Inputs **IA0** and **IA1** are analog-inputs, designed for connection of PT100 temperature probes. Temperature can be monitored in steps of 0,1°C over the complete DIN-certified range for PT100 sensors, which is -200 ... +850 °C.

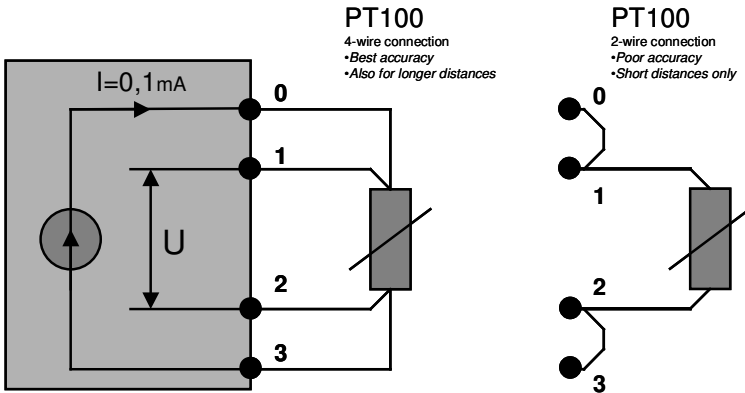

Hint

Appropriate cabling at the analog inputs is vital to avoid any negative influence on the metering process.

Use shielded twisted-pair cables, to avoid inductive and capacitive coupling. For long cable lengths, grounding of the shield should be done only at one end of the cable, in order to avoid equalization currents.

Temperature / humidity - measurement

The MFC provides the possibility to connect an external probe, which covers a combined temperature / humidity sensor. This sensor is available as an accessory under product code **ETH**.

The temperature measurement is defined as analog input IA2. The humidity measurement is defined as analog input IA3.

The sensor is an active device sending the measuring values as a digital telegram. Plausibility of the measuring values is monitored by a checksum. Invalid measuring values are ignored.

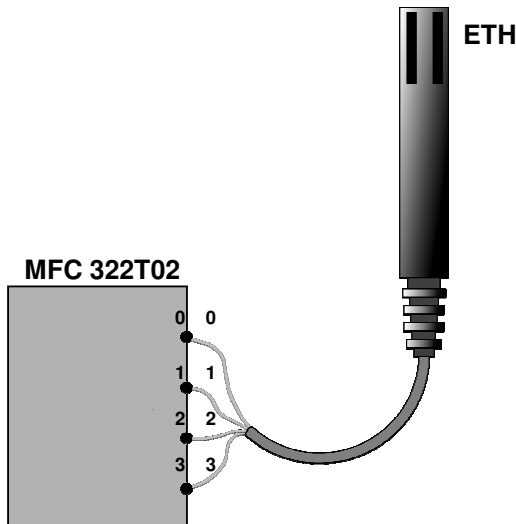

Outputs

Relay - outputs

Outputs **Q0** and **Q1** are relay outputs. Relay and board are designed for voltages up to 125VAC / 60 VDC, with a maximum load of 20 W. Relays are able to lead a maximum current of 1 A. When intended to control loads in this order or above, additional relays or power contactors have to be applied. **Relay-outputs may not be connected in parallel in order to increase load capacity.**

The state of each output is displayed by a coordinated LED on the board.

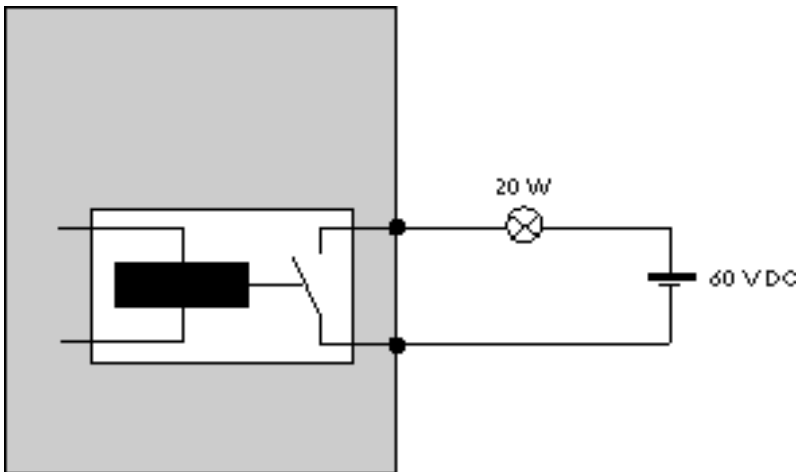

fig. 5 – Relay-outputs



Attention !

When applied with voltage ranges that exceed the low-voltage range of 24VAC or 60VDC, the MFC-board has to be installed in a suitable enclosure or distributional board, that prevents accidental contact with live parts.

Hardware-reset



Danger of electric shock !

Make sure not to touch any live part when resetting the board

In order to reset the board parameters to factory default, proceed as follows:

- Power the board and bridge points A and B for a moment. Please be careful not to touch any component. The board may be damaged due to static discharge.

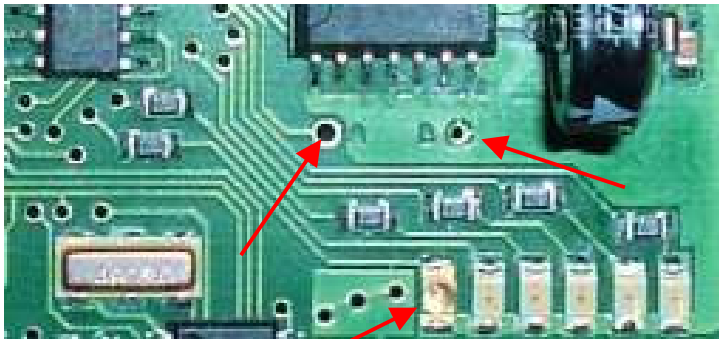

Status LED

fig. 8 - Hardware-reset

- Wait until the status-LED flashes with 1 Hz.
- Disconnect power for a few seconds.
- Power-on the board again.

All board-parameters are set to factory default now.

3. Ethernet connection

Point-to-point connection

If you want to make a point to point connection between PC and MFC, use a so called cat. 5 “cross-over”-cable with RJ45-connectors. Transmit- and receive lines are connected crosswise in this cable.

Network connection

If you want to connect the MFC to an existing network, connect it to the next switch or hub using a so called cat. 5 “patch-cable” with RJ45-connectors and straight connected lines.

Connecting the W-LAN antenna (only MFC 322T02-DC-WLAN)

The MFC is supplied with a dipole-antenna, which has to be plugged in the RP-SMA connector on the board.
Alternatively an external antenna may be connected by means of a coaxial-cable. Suitable WLAN-antennas may be ordered from us or may easily be found on the computer market.

4. Installation and putting into operation

Installation

To install the MFC, proceed in the following order:

- Mount MFC mechanically on its intended place. You may use either screws or a DIN-rail housing.
- Wire the inputs
- Wire the outputs
- Connect the power supply

Avoid touching components or circuits on the board. The board might be damaged due to static discharge.

When installing the MFC (WLAN only) inside a metallic housing, use an external antenna connected to the board with the aid of an coaxial cable.

Readiness

After connecting the power supply, the MFC-board is ready to use and may be addressed through the Ethernet-interface.

Status display

The status-LED on the board indicates its operational status. There are 4 different cases:

- | | |
|----------------------------|---|
| Constantly lighted: | The MFC is powered and is passing a selftest. After applying power, the MFC passes a self-check routine and loads parameters from permanent RAM. This may take a few seconds. |
| Flashing slowly (1 Hz): | Error condition. User intervention is required. This condition appears after resetting the MFC. Cut the power supply for a moment. |
| Short (regular) flashes: | The MFC works normally. Communication is idle. |
| Short (unregular) flashes: | The MFC works normally. Communication is in process. |

Retention

Board parameters are stored in the non-volatile memory, when power is switched off.

5. Technical Data

General	
Dimensions [mm]	(72 x 110) mm
Weight [g]	103 (WLAN); 94 (LAN)
Mounting	35mm DIN-rail (Accessories required) or through screw holes
Ambient temperature	0 to 40 °C
Relative humidity	10 to 85%, no condensation
Type of protection	IP00
Supply voltage	12 ... 24 VDC (+/- 10 %)
Power loss	Typ. 2W (LAN); 3W (WLAN)
Digital – Inputs	
Number	3
Electric isolation to power supply	No
Input voltage	Input voltage 5...24VDC
Input current	Approx. 0,5 mA (24VDC)
Counter frequency	Max. 50 Hz
Counter range per input	2 [^] 31
Temperature – Inputs	
Number	0...2
Electric isolation to power supply	No
Input type	PT100 acc. to DIN IEC 60751
Connection type	2-wire or 4-wire
Resolution	0,1 °C
Metering range	(-200 ... +850) °C
Accuracy	+/- 0,3 °C
Sample rate	Approx. 3 Hz
Combined temperature & humidity input	
Number	1
Sensor type	ETH
Temperature range	-40 ... +80
Accuracy	+/- 0,3 °C
Humidity range	(0...100) %RH
Accuracy	+/- 2 %RH
Sample rate	Approx. 3 Hz

Relay – Outputs	
Number	2
Type	Reed-relays, 1 NO-contact
Electric isolation to power supply	Yes, 125 VAC
Rated voltage	125 VAC / 60 VDC
Max. current	1 A
Max. load	20 W
Parallel connection	Not allowed
Mechanical life span	5 x 10 ⁶ cycles
Ethernet Interface (MFC 322T02-DC- LAN)	
Compliant to	IEEE 802.3
Data rate	10/100 Mbps
Connector	RJ-45, Category 5
Wireless LAN Interface (MFC322T02-DC -WLAN)	
Compliant to	IEEE 802.11b
Data rate	11 Mbps
Emission power	16 dBm
Encryption	WEP / WAP (128 Bit)
Antenna connector	1 x RP-SMA
Antenna length	108 mm

Dimensions [mm]

